

### PARTS LIST

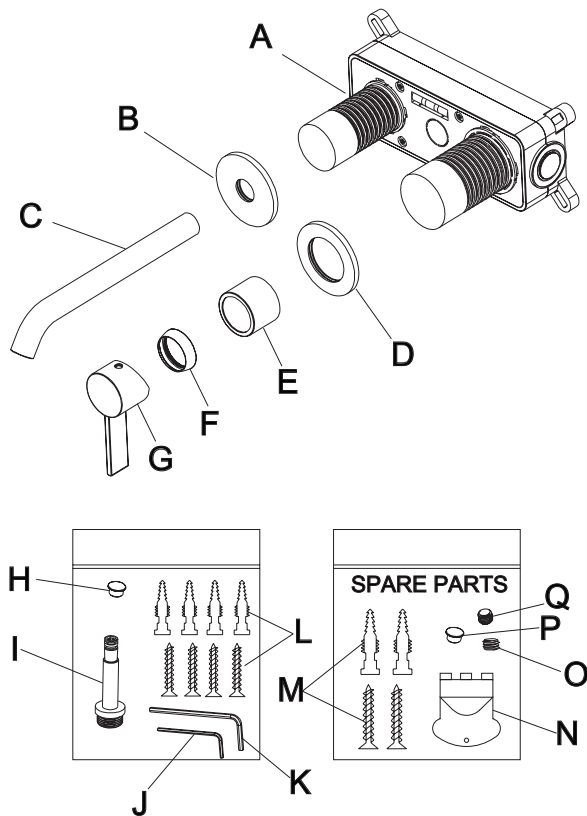

### DIMENSIONAL DRAWING

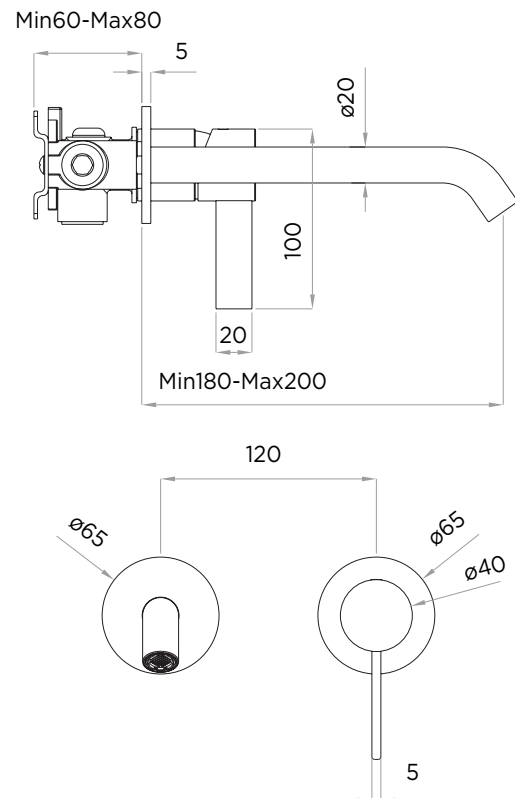

### TECHNICAL PARAMETER

Maximum working pressure of 6 bar.

The recommended working pressure is 3 bar (if the water pressure exceeds 6 bar, it is recommended to install a pressure reducing valve).

To ensure optimal operation of the product, the inlet pressure (hot and cold water) must be balanced, with a pressure difference not exceeding  $\pm 0.5$  bar

### INSTALLATION STEPS

