

### PRODUCT DESCRIPTION

#### SPECIFICATION:

1. AFTER YOU OPEN THE PACKAGE, PLEASE CHECK THE PHYSICAL OBJECT AND THE CORRESPONDING ACCESSORIES.
2. THE PICTURE IS ONLY FOR REFERENCE, PLEASE MAKE THE OBJECT AS THE STANDARD.
3. ACCESSORIES ARE SUBJECT TO CHANGE WITHOUT AFFECTING USE, NO FURTHER NOTICE.
4. THANK YOU FOR CHOOSING OUR PRODUCTS.

#### THE LIST OF PRODUCTS IS AS FOLLOWS:

PLEASE REFER TO THE FIGURE ON THE RIGHT

NO	NAME	QTY	MATERIAL	REMARK
05	SPARE PARTS	1	S.S	
04	ACCESSORY BAG	1	S.S	
03	HANDLE	1	CU	
02	PANEL	1	CU	
01	BODY	1	CU	

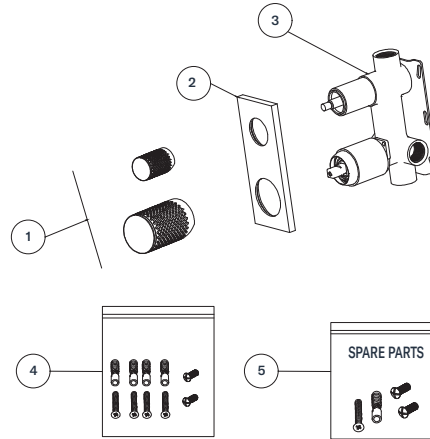

### DIMENSIONAL DRAWING

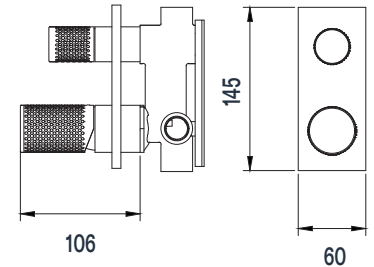

### INSTALLATION NOTES

#### IMPORTANT TIPS:

- 1.1 PRESSURE: UNDER THE PRESSURE  $0.1 \pm 0.01$  MPA, SPOUNT WITH ATTACHMENT FOR BASIN MIXER, SINK & KITCHEN MIXER, FLOW RATE  $\leq 0.1$  L/S.
- 1.2 PRESSURE: UNDER THE PRESSURE  $0.3 + 0.02$  MPA, SHOWER MIXER, FLOW RATE  $\geq 0.33$  L/S, BASIN MIXER, BIDET, SINK & HEADSHOWER, FLOW RATE  $\geq 0.15$  L/S.
2. RECOMMENDED WATER INLET TEMPERATURE  $4^{\circ} - 80^{\circ}$ .

#### NOTES:

1. BE SURE TO REMOVE IMPURITIES AND SLUDGE FROM PRE-BURIED PIPES BEFORE INSTALLING FAUCETS.
2. AFTER INSTALLING THE FAUCET, PLEASE CHECK THE JOINTS WHETHER ARE TIGHTLY CONNECTED AND THE PIPE IS LEAKING OR NOT.
3. WHEN USING, PAY ATTENTION TO WATER HOSE SHOULD NOT BE IN TORSIÓN TO AVOID HOSE RUPTURE.

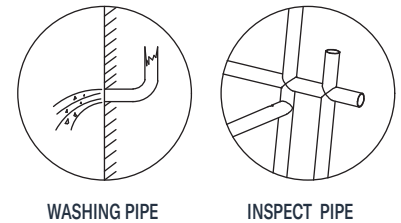

### INSTALLATION STEPS

**!**

1. THE MINIMUM DIMENSION OF WALL OPENING FOR EMBEDDED PART IS 160×80MM, WITH A DEPTH OF 60-88MM, 65-785MM IS THE BEST. (PART A IS 55-70MM; PART B IS 65-78MM). (NOTE: DEPTH DIMENSION IS REFERS TO THE WALL WITH PAVED TILE, AND PLEASE RESERVE APPROPRIATE TILE THICKNESS IF INSTALLED ON THE BLANK WALL.)
2. THE COLD & HOT WATER PIPE MUST BE CONNECTED AS SHOWN.
3. AFTER WATER TESTING, MAKE SURE THERE IS NO LEAKAGE, THEN THE PIPELINE AND EMBEDDED PARTS CAN BE COVERED WITH CEMENT FILLER.
4. THE DIMENSION OF COVERED TILE MUST BE LESS THAN THE FAUCET PLATE (145X60MM).